

Tamil Nadu Solar Net-metering

Consumer Guide

Introduction

Solar net-metering was announced in the Tamil Nadu Solar Energy Policy 2012 and forms an integral part of that policy. Consumers who plan to install grid-connected solar PV systems can apply for solar net-metering. This Consumer Guideline for solar net-metering explains the process.

Solar net-metering explained

In grid-connected solar PV systems the solar energy produced by the solar panels is converted to AC (alternating current) by a solar grid inverter. The output of the solar grid inverter is connected to the distribution board switch board of the building. The electrical energy flows to the loads of the buildings (lights, fans, appliances etc.). If the solar energy produced is more than what the building loads consume, the surplus energy will automatically be exported to the TANGEDCO distribution network (the grid). If there is less solar energy than what the loads of the building require, the shortfall will be drawn from the grid (energy import).

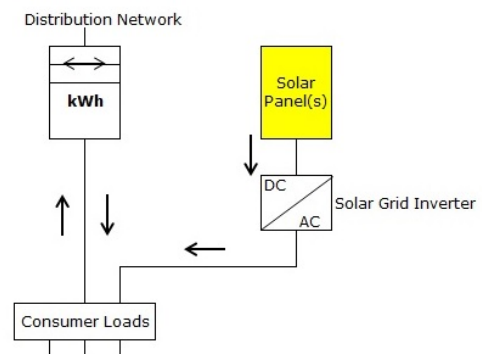

The Service Connection Meter

For solar net-metering to be implemented the existing TANGEDCO service connection meter needs to be replaced with a meter that can measure both energy import (from the grid to the consumer) and energy export (from the consumer to the grid). These meters are known as bidirectional energy meters or import-export energy meters.

The Electricity Bill with Solar net-metering

With solar net-metering the Consumer pays for the difference between import and export energy (the net-metered energy). *Example:* a Consumer imports during a billing cycle 900 kWh (units) and exports 500 kWh. The electricity bill will be for 400 kWh. If the export energy exceeds the import energy, the excess of import kWh will be carried over to the next billing cycle. During a 12 months period (the Settlement Period) the maximum of energy export that will be credited by TANGEDCO is 90% of the energy import. *Example:* During the settlement period there is a total import of 5,000 kWh and a total export of 6,000 kWh. Of the 6,000 kWh exported 4,500 kWh is eligible for adjustment with the import kWh (90% of 5,000 kWh).

Solar PV System Capacity

The solar PV system capacity shall not be more than the sanctioned load of the service connection. It is also advisable to have a solar PV system size that has an annual estimated generation of not more than 90% of the estimated consumption (see above).

Getting a Solar net-metering connection – Five steps

Step 1 - Application

Make an application to the office of the Executive Engineer (O&M) of TANGEDCO of your area. The Executive Engineer (O&M) acts as the Nodal Officer for solar net-metering. Your application will be registered in a computerized data base and you have to pay the registration fee of Rs. 100.00. You will get a signed acknowledgment. For HT (high tension) service connections the application needs to be registered by the Superintending Engineer of the distribution circle.

Step 2 – Technical Feasibility

TANGEDCO will verify the technical feasibility of connecting your solar PV system to their distribution network. For this TANGEDCO applies two criteria:

- The total solar PV capacity in the local distribution network (existing and proposed) shall not exceed 30% of the distribution transformer capacity. *Example:* A distribution network that is served by a 250 KVA distribution transformer cannot have more than 75 kW of total solar PV capacity connected to it.
- The proposed solar PV system capacity cannot be more than the sanctioned or contacted load of the service connection. If the proposed solar PV capacity is more than the service connection sanctioned load, you first have to apply for service connection load enhancement and then submit your solar net-metering application.

If TANGEDCO finds that your proposed solar PV system can be connected to their local distribution network, you will receive from them a Technical Feasibility Intimation letter. This letter will be sent to you within 10 working days from the date of your application.

Step 3 – Solar PV system installation and readiness intimation

You can now procure and install the solar PV system. This has to be done within 6 months from the date of the Technical Feasibility Intimation letter. This period can be extended by another 3 months upon written request if system procurement has been completed and installation work is in progress. Upon completion of the solar PV system installation work you intimate your readiness to the Executive Engineer (O&M) of TANGEDCO.

Step 4 – Safety Inspection

Within 10 days from the date of receiving your readiness communication, your solar PV system will be inspected for safety. For solar PV systems up to 10 kW this will be done by TANGEDCO and for systems above 10 kW this will be done by the Electrical Inspector of your area. Within 5 days from the date of inspection you will receive a Safety Certificate if the installation complies with the technical requirements (see annex 1).

Step 5 – Service connection meter replacement and commissioning

TANGEDCO will replace the existing service connection meter with a bidirectional service connection meter for which you have to pay meter replacement charges. TANGEDCO permits the Consumer to procure the bidirectional meter and will publish on their website a list of approved meter makes and types.

Annexe 1

Safety Requirements for Grid-connected solar PV systems

1. The solar grid inverter shall stop feeding power into the loads and the TANGEDCO grid when the TANGEDCO grid fails or is switched off for maintenance. For this the solar grid inverter shall have built-in anti-islanding protection. This protection ensures that the solar grid inverter cannot operate in island mode. The anti-islanding protection can be tested by switching off the service connection main switch, or by removing the meter fuses, and check whether there is voltage on the consumer side of the service connection main switch or meter fuses. If there is no voltage, the anti-islanding protection is functional.
2. The solar PV system shall have its own separate earthing system and shall be provided with lightning protection.
3. It is advisable (not mandatory) to install surge protection devices on both the DC side and the AC side of the solar grid inverter.
4. The Consumer shall fix a caution sticker of 10 x 7 cm on the service connection main switch and near the service connection meter with the following text: "**Solar PV System**". The letters shall be white on a green background. TANGEDCO will fix similar stickers on the service connection pole and elsewhere in the distribution network. Additionally, the Consumer shall fix a caution sticker near the service connection meter with the following text: '**This service is fitted with an LT grid-connected Solar PV plant**'.